

RS 58 series

- Small foot print
- Synchro-Flange mounting
- Solid shaft
- Line counts up to 5,000
- Typically used for motor feedback and positioning, robotics, and conveyors



Compatible with:

- Heidenhain ROD 400 Series - ROD 426, ROD 456, ROD 486
- Fagor S and SP series

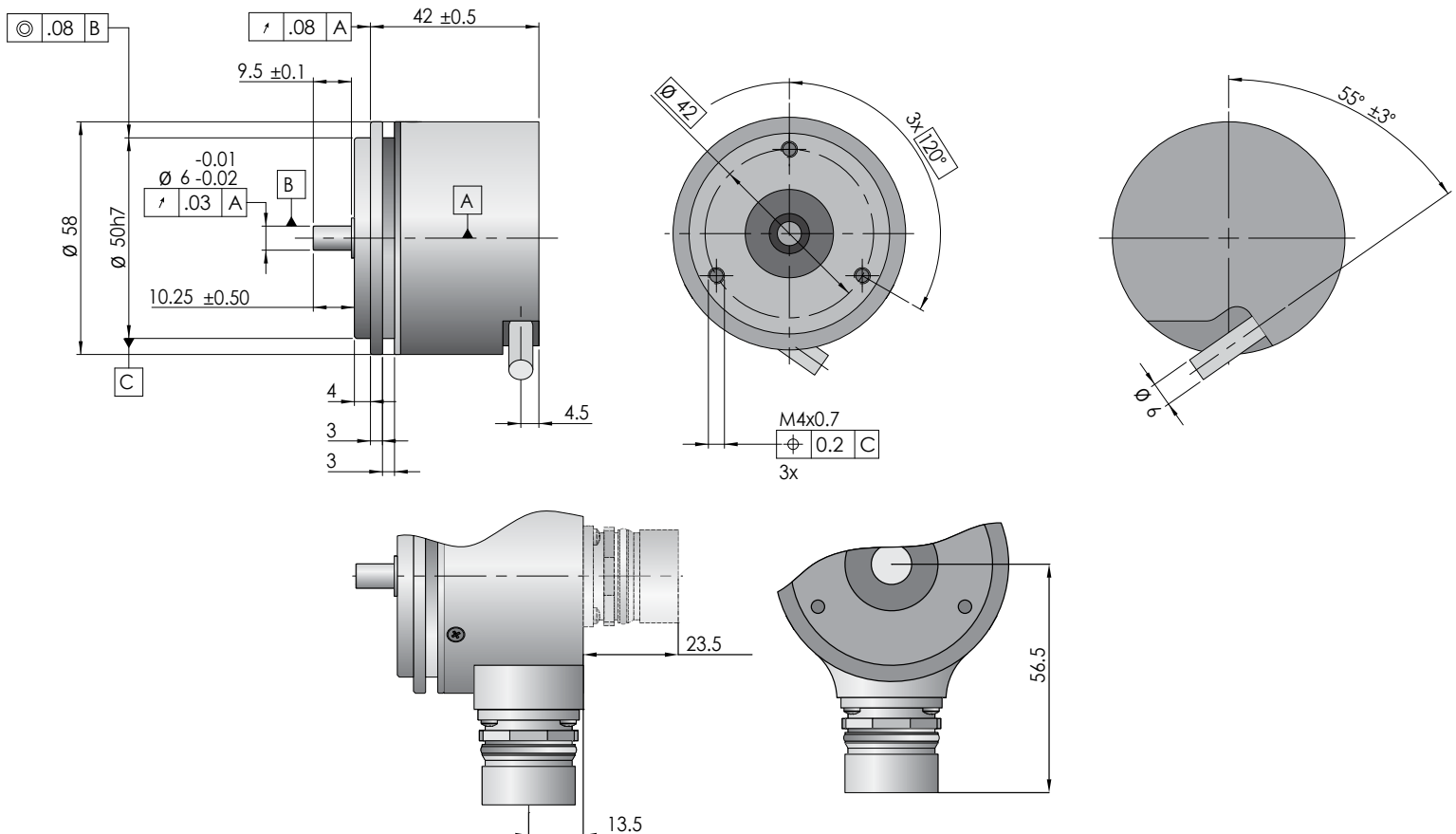

RS 58 series

	RS 5801	RS 5802	RS 5805	RS 5810	RS 5800	RS 5811
Line count	1000, 1024, 1250, 2000, 2048, 2500, 3600, 4096, 5000					
Pulses per revolution	1x line count	2x line count	5x line count	10x line count	1x line count	1x line count
Output Signal	TTL/RS422				1 Vpp	11 uA
Max. output frequency	≥ 160 kHz	≥ 320 kHz	≥ 800 kHz	≥ 1 MHz	≥ 180 kHz	≥ 180 kHz
Max. mechanical speed	12,000 RPM					
Accuracy grade	1/10th of the grating period					
Reference mark	Single					
Max. axial load	1 kg					
Max. radial load	2 kg					
Supply voltage	5 V ± 5%					
Supply current (without load)	≤ 120 mA					
Outlet type	Cable or housing connector (12 pin round)					
Max. cable length	100 m				150 m	5/25**m
Environmental protection	IP64 (IEC 60529)					
Operating temperature range*	-20°C...+70°C					
Storage temperature range	-30°C...+80°C					
Humidity	98% (non-condensing)					
Vibration (55 ÷ 2000 Hz)	≤ 100 m/s ² (IEC 60068-2-6)					
Shock (6 ms)	≤ 1,000 m/s ² (IEC 60068-2-27)					
Weight (without cable)	Approx. 0.3 kg (0.7 lb)					
Rotor moment of inertia	≤ 2.5 · 10 ⁻⁶ kgm ²					
Starting torque	≤ 0.01 Nm					

*for best accuracy, operating outside 0°C...+50°C is not recommended

**combined length from encoder to interpolator box and from the interpolator to controller

How to Order example: RS 5805-3600-4

RS 58XX

-XXXX

-X

Model

- RS 5800
- RS 5801
- RS 5802
- RS 5805
- ...

Line count

- 1000, 1024, 1250, 2000, 2048, 2500, 3600, 4096, 5000

Outlet type

- C - housing connector
- 1 - 1m cable
- 2 - 2m cable
- 3...